



Mass Rapid Transit Corporation Sdn Bhd (902884V)
Tingkat 5, Menara I&P 1
46 Jalan Dungun, Bukit Damansara
50490 Kuala Lumpur

APPLICATION GUIDELINE

APPLICATION TO RENT RETAIL SPACE AT MASS RAPID TRANSIT (MRT) FOR MASS RAPID TRANSIT CORPORATION SDN BHD

While every reasonable care has been taken to provide the information in this Guideline, MRT Corp makes no representation whatsoever on the accuracy of the information contained which is subject to change without prior notice. MRT Corp reserves the right to make amendments to this Guideline from time to time as necessary. MRT Corp accepts no responsibility and/or liability whatsoever for any reliance on the information herein and/or damage howsoever occasioned.

TABLE OF CONTENTS

1	INSTRUCTIONS TO APPLICANTS.....	3
1.1	Introduction.....	3
1.2	Purpose.....	3
1.3	Scope of Proposal.....	3
1.4	Application Document.....	3
1.5	Preparation & Submission.....	4
1.6	Other Terms and Conditions.....	6
2	TERM OF REFERENCE.....	13
2.1	About Retail Spaces at MRT.....	13
2.2	Criteria for Applicants.....	13
2.3	Eligible Parties.....	13
2.4	Evaluation of Proposal.....	13
2.5	Terms and Conditions of Proposal.....	14
2.6	Licence Fee and Service Charges.....	17
2.7	Retail Space for Rent.....	18
2.8	Retail Floor Plan.....	20

1 INSTRUCTIONS TO APPLICANTS

1.1 Introduction

Mass Rapid Transit Corporation Sdn Bhd (“MRT Corp”) is fully owned by the Ministry of Finance Incorporated and the Federal Lands Commissioner to facilitate, undertake and expedite the Klang Valley Mass Rapid Transit (“KVMRT”) project and was appointed the developer and asset owner of the same.

The first Mass Rapid Transit (“MRT”) line, the Kajang Line (“KG Line”) which was fully operational in July 2017, serves communities along its 51KM alignment with 31 stations and 14 park and ride facilities. The second line, Putrajaya Line (“PY Line”) will have a length of 52.2km, consisting of 35 stations of which Phase One from the Sungai Buloh Station to the Kampung Batu Station will begin operations in July 2021, while the rest of the line from the Kampung Batu Station to the Putrajaya Sentral Station will be operational under Phase Two in January 2023.

1.2 Purpose

The purpose of this Retail Space Application is to engage registered, experienced and qualified Business Owners to be granted a licence to operate its business in the retail spaces at MRT Putrajaya Line (PY Line).

This **Instructions to Applicants (“ITA”)** shall be complied with strictly and shall be used as the basis for the preparation and submission of the proposal. Non-compliance by any applicants on any of the stipulated in this document shall entitle MRT Corp at its sole discretion to disqualify the applicant. The applicant undertakes and covenants that they have no right to sell or disclose any information contained in the Application Document to any third party.

1.3 Scope of Proposal

The scope of proposal is as specified in the **Terms of Reference (“TOR”)** in **Item 2** of this Application Guideline.

1.4 Application Document

The Application Document shall comply with the following: -

- a) Application Guideline
- b) Application Form
- c) Licence Agreement
- d) MRT Fit-Out and Design Guideline

All expenses which may arise due to compliance with the instructions or conditions herein shall be deemed to have been reflected by the applicant in its proposal. Any non-compliance by the applicant on any of the requirements stipulated in this Application Document shall entitle MRT Corp, at its sole discretion to disqualify the applicant. Notwithstanding anything to the contrary contained in this Application, the interpretation of its contents by MRT Corp shall be final.

1.5 Preparation & Submission

1.5.1 The Quotation shall be submitted in **FIVE (5)** distinct parts as follows:-

1. **BASIC DOCUMENT**
2. **VOLUME 1 – TECHNICAL SUBMISSION**
3. **VOLUME 2 – COMMERCIAL SUBMISSION**
4. **VOLUME 3 – FINANCIAL SUBMISSION**
5. **VOLUME 4 – LEGAL SUBMISSION**

1.5.2 Bidder shall submit its Quotations in **two (2) complete sets** in the following forms:-

(a) One (1) set of the ORIGINAL copy;

Each Volume (Basic Document, Volume 1, Volume 2, Volume 3 & Volume 4) of the original copy shall be initialled on every page and stamped on the cover and marked as **“ORIGINAL”**.

(b) One (1) set of the DUPLICATE copy;

Each Volume (Volume 1, Volume 2, Volume 3 & Volume 4) of the duplicate copy of the ORIGINAL shall be submitted and marked as **“DUPLICATE”**.

However, Volume 1, Volume 2, Volume 3 & Volume 4 of the DUPLICATE shall be submitted WITHOUT any reference being made to the Bidder and/or its organisation. It shall be the responsibility of the Bidder to ensure that all reference and indication being made to the Bidder and/or its organisation to be obliterated in totality. Bidder must ensure that each Section of the duplicate copy is identical true copy of and processed from the ORIGINAL.

The Proposals shall be marked as follows: -

APPLICATION TO RENT RETAIL SPACE AT [UNIT NO.] FOR THE MASS RAPID TRANSIT PUTRAJAYA LINE (MRT PY LINE) FOR MASS RAPID TRANSIT CORPORATION SDN BHD”

Failure on the part of the applicant to comply with the requirements stipulated herein may render the submission as being non - compliant and MRT Corp reserves the rights to disqualify the non-compliant applicant without having to provide any reason whatsoever.

1.5.3 Submission Deadline

All proposals shall be submitted before the deadline **25 June 2021 (“Closing Date”)** **not later than 12.00 pm (“Time”)** at MRT Corp Sdn Bhd addressed as below: -

**Procurement Counter,
Mass Rapid Transit Corporation Sdn Bhd (“MRT Corp”)
Level 6, Menara I & P 1,
No. 46, Jalan Dungun Bukit Damansara,
50490 Kuala Lumpur**

The submission of the proposal shall be delivered in hardcopy **BY HAND** and submitted to **Procurement Department** office on or before the Closing Date and Time. Courier or faxed or e-mailed Proposals **SHALL NOT** be accepted. Any document left out and/or not included in the submission envelope, **SHALL NOT** be accepted. Any document received after the Closing Date and Time specified herein will not be accepted.

1.5.4 Bidding

Applicants are required to fill their bid price for the retail space specified in the Form of Proposed Bid.

1.5.5 Failure of Applicant

Failure on the part of the applicant to comply with the requirements of **item 1.5** above hereof may render the submission as being non - compliant and MRT Corp reserves the rights to disqualify the non-compliant applicant without having to provide any reason whatsoever.

1.5.6 Request for Clarification

- a) Any request for clarification/additional information with regards to this Application should be made in writing through email to: -

Email: - procurement@mymrt.com.my

- b) All clarification of information pursuant to the Application SHALL only be made by way of email as per **item 1.5.4 (a)** above and shall reach Procurement Department not later than **THREE (3) DAYS PRIOR** to the submission deadline ('Closing Date').
- c) MRT Corp shall not entertain any clarification received beyond the stipulated period including any verbal request made by the applicant for any clarification of information. MRT Corp shall not be held responsible and/or liable for any response to the clarification of information duly obtained by the applicant other than the Business Development Department be it in written or verbal form.
- d) All proposals submitted shall incorporate all requirements and/or information prescribed in the said clarification(s) and/or addendum(s) duly issued by the Procurement Department.
- e) The applicant covenants that it shall have no recourse by whatsoever means against MRT Corp, its employees and/or agents for any delay arising from the response(s) to the clarification of information and/or issuance of addendum(s) which may result in the applicant's inability to complete and/or submit the proposal by and/or before the Closing Date and Time.

1.5.7 Addendum to the Application Document

- (a) MRT Corp may at its sole discretion issue Addendum(s) to the Application Document before the Closing Date which may in effect vary, amend, increase and/or reduce the requirement(s) in the submission of the proposal. The applicant shall only respond to Addendum(s) issued by the Business Development Department. Any variation(s), amendment(s), increase and/or reduction in the requirement of the Application Document forwarded by any other personnel other than Business Development Department SHALL NOT be a valid Addendum issued by MRT Corp
- (b) The applicant shall be required to revise, amend, modify and/or clarify any part of its proposal in accordance with the Addendum(s) issued.
- (c) Every addendum issued shall form part of this Application document and the proposal shall include all the requirements of the said Addendum(s).
- (d) It is the applicant's sole responsibility to ensure that it has duly verified receipt of a complete Application document, inclusive of all Addendum(s) (if any). Proposal submitted shall be deemed to have been made in reference to and on the basis of the entire Application document, inclusive of all Addendum(s) duly issued prior to the Closing Date and Time.

1.5.8 Holding Company Guarantee

If the applicant's proposal is based upon the capabilities of its holding/parent company, MRT Corp would require a Letter of Undertaking from its holding/parent company that it shall provide a Holding/Parent Company Guarantee if the Applicant is the successful applicant.

1.6 Other Terms and Conditions

1.6.1 Licences, Certificates and Permits

The applicant covenants that it shall assume full responsibility in obtaining and/or holding all rights, licences, certificates, permits, consents, approvals and authorities issued by any level of government and/or private agency(s) required to carry out the services and perform the contract, except as otherwise stated in this Application Document.

1.6.2 Liaison with Authorities

Under no circumstances shall the applicants liaise directly with any authorities with regards to their Proposal without prior notification from MRT Corp

1.6.3 Applicants to Fully Inform Himself

It is emphasized that it shall be the responsibility of the applicants' to be self-informed fully of the proposal requirements and to familiarize themselves as to the form and nature of the proposal necessary for the completion of the proposal and in general shall themselves obtain all necessary information as to the risks, contingencies and other circumstances which may affect their submission.

1.6.4 Expenses

The applicant covenants that it SHALL be solely responsible for all of its costs and expenses in relations to its participation directly and/or indirectly in the Application exercise from the date of receipt of the Application document up until the Closing Date, and any subsequent processes of negotiation(s) and/or clarification with MRT Corp All expenses, which may arise due to compliance with the instructions or conditions herein, shall be deemed to have been reflected by the Applicant in its proposal.

1.6.5 Acceptance of Proposal

MRT Corp's receipts of the proposal document are conditional upon the applicant's acceptance of the conditions that MRT Corp's imposed on the successful applicant. MRT Corp's decision on the successful applicant shall be final and the Applicant agrees that:-

- a) MRT Corp reserves the right to accept and/or reject any or all proposal documents, to undertake decision to appoint one or more applicants for the whole or a portion of the development involved and/or to accept or modify at its sole discretion and may make judgment most advantageous to MRT Corp, after considering the capacity, quality and other evaluation factors without assigning any reason thereof.
- b) MRT Corp reserves the right to accept and/or reject in whole or in part of the proposal submitted and not obliged to give any reason for the non-acceptance or rejection of any proposal submitted.
- c) MRT Corp shall not be bound to accept the proposal of the applicant offering the highest bid.
- d) ITA of the Application Document is based on the current requirements. MRT Corp reserves the right to increase or decrease the requirements depending on demand within the contract period.
- e) This Application SHALL NOT be construed as an intention to create a legally binding contract between MRT Corp and the applicant. MRT Corp is under NO obligation whatsoever to award and/or enter into a contract with the applicant, including the obligation to award to the highest bid.



- f) The applicant understands that the acceptance of the proposal submitted is part of MRT Corp's evaluation process and in NO event whatsoever be interpreted and/or construed as an acceptance amounting to an appointment.

1.6.6 The validity of the Proposal

Proposals submitted SHALL be valid for a period of **One Hundred and Eighty (180) days** from the Closing Date. MRT Corp shall have the right to extend the validity period in the event that the appointment could not be made within the said period. MRT Corp SHALL NOT entertain any changes to the applicant's proposal and any other conditions by reason of the extension of the validity period.

1.6.7 Annulment Process by MRT Corp

- (a) MRT Corp reserves the right to annul this Application exercise and reject all proposals without providing any reason whatsoever for such rejection at any stage of the Application exercise. MRT Corp reserves the right at any time to annul the application without being liable for any costs, damages, losses and/or expenses whatsoever.
- (b) All applicants fully understand and accept that it shall have no legal recourse against MRT Corp, its employees and/or agent for such annulment and/or rejection in any respect whatsoever

1.6.8 Conflict of Interest

All applicants shall make a declaration in the event any members of the family are employed by MRT Corp to ensure that the said employee abstains from participating, deliberating and or have any form of involvement in the decision making of this Application. The Applicant shall sign and submit together with its proposal the "Conflict of Interest or Relationship Disclosure Statement " appended in the Application Form.

1.6.9 Non-Collusion

- (a) The applicant, its employees, agents and/or representative covenant that they SHALL NOT discuss and/or communicate with any other Applicants with regards to the preparation of its Proposal.
- (b) No applicant, its employees, agent and/or representative shall have any direct or indirect interest whatsoever in the proposal of a third-party applicant(s), or enter into any arrangement which, in the assessment of MRT Corp, tantamount to the creation of such interest. Should any of the above interest or arrangement be discovered at any stage of the Application exercise, the applicant understands, acknowledges, and accepts that MRT Corp SHALL at its own discretion without providing further reasoning(s) either before and/or after the Closing Date and Time disqualify the proposal and/or terminate the award of contract.

1.6.10 Non-withdrawal of Proposal

Proposal submitted cannot be amended or withdrawn for any reason whatsoever. Each proposal submitted shall remain irrevocable and valid for MRT Corp's acceptance for a period of one hundred and Eighty (180) days from Closing Date or such other date as may be determined by MRT Corp at its discretion and as notified to the applicant. Any submission not properly completed shall be rejected at MRT Corp's sole discretion.

1.6.11 Anti-Bribery Representation, Warranty and Covenant

- (a) The Applicant hereby represents and warrants to MRT Corp, that (i) the Applicant has not made or offered to make or offer and (ii) none of the persons associated with the Applicant, has made or offered or to make or offer, any compensation, commission, agency fee, introduction fee, payment, gift, promise or advantage from the Applicant or the person associated with the Applicant to any third party where such payment or advantage would violate applicable laws (or the laws of incorporation of MRT Corp) with the view of influencing the acceptance of the Application.
- (b) The Applicant agrees that any offer of compensation, commission, agency fee, introduction fee, payment, gift, promise, advantage or bribe or other inducement by the Applicant to any individual, corporation, partnership, joint venture, trust, unincorporated organisation or any governmental entity by the Applicant or any person associated with the Applicant may result in instant termination of this Letter without any compensation or a claim for damages for such termination.
- (c) The Applicant acknowledges that MRT Corp has adopted the policies, guidelines and procedures which are available within MRT Corp's website www.mymrt.com.my ("**MRT Website**"). The policies, guidelines and procedures as well as other policies, guidelines and procedures related to anti-bribery, anti-corruption and ethical or proper conduct as may be uploaded by the MRT Corp onto MRT Website from time to time (collectively called "**the said Policies**") may be amended, supplemented, varied or replaced from time to time.
- (d) The Applicant shall regularly and diligently familiarise itself and procure that persons associated with the Applicant are regularly and diligently familiarised with the said Policies, including all amendments, supplements, variations or replacements thereof from time to time and shall not do anything or omit to do anything (including the persons associated with the Applicant) that will cause any employee, servant or officer of MRT Corp to be in breach, default or non-compliance of the said Policies.

1.6.12 No Lobbying

The applicant is forbidden from lobbying any of MRT Corp employees, agents and/or representatives with regard to the Application exercise. Failure to comply with this requirement may lead to disqualification of the applicant's participation in the Application exercise without MRT Corp having to provide further notice.

1.6.13 No Claim Clause

- (a) MRT Corp reserves the right to award the contract to the applicant deemed to have the most attractive proposal. MRT Corp also reserves the right NOT to make any award of the contract to anyone of the applicants. The applicant understands the contents of this **item** and hereby covenants by completing the Statement of Compliance to the Instructions to the applicant, the applicant has in effect waive all rights to protest and/or make any claim against MRT Corp for any decision and/or contract awarded or not awarded pursuant to the Application exercise.
- (b) MRT Corp shall not be responsible for any expenses incurred in connection with the preparation, loss or delay in the delivery and submission of documents and information related to the Application exercise. The applicant will not be reimbursed for any expenses incurred by it in the preparation of the proposal. The costs incurred shall be totally borne by the applicant.

1.6.14 Non-compliance with Instructions

Non-compliance with the ITA shall render the proposal submitted as incomplete and thus rejected.

1.6.15 Presentation of Proposal

The applicant understands and accepts that it may be required to provide a presentation(s) of the submitted proposal at its own costs when requested by MRT Corp, for the benefit of understanding the submitted proposal which may lead to a fair and just evaluation of the said proposal.

1.6.16 Form of Acceptance

The award of the licence to this Application exercise shall only be made in the form of a Letter of Offer.

1.6.17 Confidentiality

- a) All parts of the Application Document together with any addendum shall remain the property of MRT Corp and is given to the applicant solely for the purpose of the preparation and submission of the Application. The Applicant shall, whether or not he submits a Proposal, treat all details included in the Application Document as strictly private and confidential.
- b) The applicants shall keep all information contained in the Application Document confidential and under no circumstances, it is to be disclosed to any third party for any purpose other than the preparation of the proposal submission. Such disclosure is permitted to the applicants' appointed consultants, employers and partners who are working solely for the purpose of the submission of the proposal provided always that the applicants secure an equivalent undertaking of confidentiality from such third party.

- c) The applicant shall sign and submit together with its proposal the "Non-Disclosure Agreement" appended in the Application Form.

1.6.18 Ownership of Proposal

The proposal and all documentation enclosed thereto submitted to MRT Corp shall be treated as CONFIDENTIAL and becomes the property of MRT Corp upon its acceptance and shall not be returned to the applicant. MRT Corp shall have the right to utilise the information as reference only.

1.6.19 Submission by Applicant

- a) Any discrepancy(s) and/or inconsistency(s) found in the information submitted by the applicants shall be treated as inconsistent and unreliable information which shall provide MRT Corp with the right to reject unless such discrepancies shall have been resolved or satisfactorily explained within such period of time as required by MRT Corp.
- b) If the submission made by applicants contains false information, MRT Corp reserves the right to reject the proposal submission without providing any explanation whatsoever. Any proposal submission, which contains fictitious and/or fraudulent information, shall be rejected immediately.

1.6.20 Authorised Signatories

The proposal, and any undertaking in relation to the proposal, including the acknowledgement of the offer, shall be signed by one or more representative authorised by the applicant ("**Authorised Signatory**") to act on its behalf and bind the applicant. The submission of a valid Board of Director Resolution (one (1) original and one (1) duplicate copies) by each applicant is mandatory and it shall clearly state the effective date and the validity period of the Board of Director Resolution. Such authorisation shall be evidenced as below: -

- a) For a foreign incorporated company, the applicant must submit a valid Power-of-Attorney.
- b) For a local incorporated company, the applicant must submit either Board of Director Resolution and/or a valid Power-of-Attorney.

The authentication of a valid Board of Director Resolution shall be recognised as follows:

- a) The Board of Director Resolution for the respective Applicant must be certified as a true copy by the applicant's Company Director or (if applicable) Company Secretary.

All copies of documents, including certificates, and other information forming part of the proposal submission shall be certified as true copies by the applicant's Company Director or (if applicable) Company Secretary, or by the Notary Public (for

foreign/international applicant), and stamped with the Company's official stamp.

1.6.21 Headings and Captions

The headings and captions in this Application are inserted for convenience only and do not form a part of this Application and in no way define, limit, alter or enlarge the scope of meaning or any term of this Application.

1.6.22 Language

The proposal submission and any correspondences relating thereto duly prepared and submitted by the applicant shall be in the English Language.

1.6.23 Currency to be used in the Proposal

All fees, costs and other prices shall be quoted in Ringgit Malaysia (RM).

1.6.24 Opening of Proposal

MRT Corp will not open any proposals publicly. However, all applicants will be officially notified about the result of their offers upon the completion of the award process.

1.6.25 Accuracy of Bid Price

Applicants should ensure that the offered bid price is accurate before submitting their proposal. Under no circumstances will MRT Corp accept any request for an adjustment on grounds that a mistake has been made in the proposal by an applicant.

2 TERM OF REFERENCE

2.1 About Retail Spaces at MRT

Transit business is a captured market that is fast-paced and continues to be on an incline over time. Parallel to the trends of public transit around the world, the demand for mobility will continue to grow as commuters become increasingly reliant on convenient travel. That said, business offering in stations become more than product offerings. It becomes an offering of convenience. Business in a transit environment is dynamic and requires creative approaches in maintaining business sustainability. Therefore, experience and a good long-term business plan is a prerequisite to enter the transit market.

2.2 Criteria for Applicants

The retail space application is conducted by way of an application process. The criteria for applicants to fulfil to be appointed as our licensee (“**Licensee**”) are:

- a) Financially capable with proven financial records
- b) Sustainable with at least one (1) year in existence
- c) For retail at stations, a Grab and Go retail concept or a service-oriented business with a complete operations plan

2.3 Eligible Parties

The **mandatory requirements** which shall be complied within the application to participate:

- a) Your business is registered with the Companies Commission of Malaysia (SSM). Supporting documents to be provided.
- b) Your business has a minimum paid-up capital of RM 50,000.00 for lots marked (*) or RM 20,000.00 for lots marked (^). Supporting documents to be provided.
- c) Your business has at least two (2) years for lots marked (*) or one (1) year for lots marked (^) of similar/relevant/related experience to the trade applied. Supporting documents to be provided.

All supporting documents must be valid and certified. Invalid and/or incomplete documents will automatically be disqualified.

2.4 Evaluation of Proposal

Proposals will be evaluated according to the scoring system set by MRT Corp. A score shall be given according to the fulfilment and completeness of the Proposal by the applicants in accordance with the submission requirement as indicated in ITA of this Application Document. Each proposal will be given accumulative scores at each stage of evaluation. The scoring of the proposal will be based on the completeness of the submissions below.

2.4.1 Technical proposal

Applicants are required to submit a complete business proposal as specified in the Application Form.

2.4.2 Commercial Proposal

Applicants are required to fill their bid price for the retail space specified in the Form of Proposed Bid.

2.4.3 Financial Information

Applicants are required to submit a complete financial data of its current business as specified in the Application Form.

2.4.4 Corporate and Legal Compliance

Applicants are required to submit the required documents as specified in the Application Form.

2.5 Terms and Conditions of Proposal

2.5.1 Award of the Licence

A Letter of Offer will be handed to the successful applicant's address as provided in its proposal. The successful applicant is given one (1) week [or as specified by MRT Corp] to accept the award as specified in the Letter of Offer unless prior written approval has been obtained from MRT Corp for any extension. The successful applicant who does not respond within the time specified for acceptance in the Letter of Offer will be assumed not to accept the offer. For the avoidance of doubt, MRT Corp shall have the right to withdraw any award at any time without any liability before the Letter of Offer is issued to the successful applicant. MRT Corp will not enter into correspondence with any applicant regarding the reasons for non-acceptance of their proposal submission.

2.5.2 Acceptance of Changes by Applicants

The applicant accepts that there may be changes to the layout plans, floor areas, shop specifications, estimated availability dates and other details provided in this proposal.

2.5.3 Payments upon Letter of Offer

Upon award acceptance, Licensee shall sign the Letter of Offer and make the following payments:

- | | |
|----------------------------|--|
| a) Security Deposit | : Three (3) months Licence Fee |
| b) Service Charges Deposit | : Two (2) months Service Charges |
| c) Fit Out Deposit | : RM 5,000.00 or RM 250/m ² whichever is higher |
| d) Reinstatement Deposit | : Interchangeable with Fit Out deposit |

- e) Licence Fee for the First Month : Licence Fee amount or as per bid by Licensee
- f) Service Charges for the First Month : As stated in Table 2

2.5.4 Right to Enter into Private Negotiations

MRT Corp reserves the right to subsequently enter into private negotiations with any applicant or such party for any unit as deemed fit by MRT Corp.

2.5.5 Licence Period

The period of the licence shall be :

- a) Two (2) years with an option to renew for a further term of three (3) years for lots marked (*), based on payment track record and operational performance unless otherwise indicated.
- b) One (1) year with an option to renew for a further term of one (1) year for lots marked (^), based on payment track record and operational performance unless otherwise indicated.

2.5.6 Minimum Business Hours

Licensee is to ensure the business operation is in accordance with the minimum business hours as stated in the Retailer Handbook unless otherwise indicated.

2.5.7 State and Condition of the Unit

The Licensee, at their own cost and expense, is to provide signage, flooring, false ceiling, supply and return air ducts and diffusers, and 2nd layer sprinkler system (where necessary). Licensee is also required to provide own air-conditioning units to suit the operations, e.g. for extended business hours or if in use of equipment/lightings generating high heat loads, subject to Licensor's and authorities' approval. The retail space must be kept clean at all times.

2.5.8 Licence-free Fitting-Out Period

A licence-free fitting-out period of up to four (4) weeks before the commencement of the licensing will be granted to Licensee. Rent will be charged from the expiry of the licence-free period, regardless of whether the Licensee is ready for business, or from the commencement date of business, whichever is earlier. The Licensee will have to take into account renovation or other requirements in offering a monthly licence fee.

2.5.9 Fitting-Out Works

Upon such award, the Licensee undertakes and warrants to carry out fitting-out works at its own cost and expense and in compliance with the Licensee's Fit-Out Manual. The Licensee is to undertake all site preparation works (Civil and M&E works) at its own cost and expense. All design and layout are subject to MRT Corp and the relevant

authorities' approval. Licensee must ensure certifications of trained and competent contractors are available and valid for the execution of fit-out.

2.5.10 Submission of Layout and Fitting-Out Plan

The Licensee is required to submit fitting out plans and layout as detailed out in the Fit-Out Manual to MRT Corp for review and approval. MRT Corp reserves the right to reject the plans and layout if the requirements are not met.

2.5.11 Prohibited Sale Items

Sale and display of the following items are strictly prohibited within the MRT stations:-

- a) R-rated materials by illegal act with negative influence i.e. pirated, anti-racial, pornographic or related products/materials.
- b) Alcohol or any beverage with alcoholic content is prohibited unless with written consent from MRT Corp i.e. Wine, spirit, etc.
- c) Non-halal food and beverages.
- d) Flammable substance. All combustible materials can only be sold in a total amount of 2 litres in safety can(s)/fire cabinet. Only a total amount of not more than 10 litres is permitted for display purposes at any one time.

2.5.12 No Assignment, Sub-rent or Part with Possession

The Licensee will not be allowed to assign, sub-rent or part with possession of the awarded unit or any part thereof.

2.5.13 Licences, Permissions or Approvals

As required by law, the Licensee is to obtain licence, permission and approval to carry out businesses from relevant authorities. Copies of these legal document shall be submitted to MRT Corp. No allowance in payment or refund of the licence fee shall be given for any period before such licence, permission or approval is granted if the same is refused or withdrawn.

2.5.14 Non-Negotiation of Terms

All terms and conditions contained and stated in the Application Document, Licence Agreement, Retailer Handbook and Fitting-Out Manual are non-negotiable.

2.5.15 MRT Corp's Right to Inspect the Applicant's Facility

MRT Corp reserves the right to inspect the Applicant's facility by giving no less than forty-eight (48) hours' notice and the Applicant shall provide the necessary access and provide permission for MRT Corp to carry out such inspection.

2.6 Licence Fee and Service Charges

2.6.1 Licence Fee

The Base Licence Fee is the base amount for the unit specified. The Base Licence Fee is available on the MRT Corp's website (<https://www.mymrt.com.my/business/retail-space/>).

2.6.2 Service Charges

In addition to the Licence Fee, the Licensee shall pay to MRT Corp monthly Service Charges. Item 1 and 2 in the table below are the items covered under Service Charges to be paid by the Licensee.

No.	Item	Description
1	Electricity	According to usage, as charged by the Operator/Service Provider
2	<ul style="list-style-type: none"> • Facilities Management • Waste Management • Building Services 	According to size and location
3	*Quit rent Charges	As charged by Local Council
4	*Assessment tax	As charged by Local Council

***To be charged every 6 months or as and when charged by Local Council.**

Table 1: List of services to be paid by the Licensee.

- a) Electricity charges forms part of the Service Charges. Applicants hereby acknowledge that the electricity usage by the Licensee is charged by the Operator/Service Provider to MRT Corp for the usage of electricity at the retail space.
- b) Electricity charges imposed will be according to the type of trade. The table below shows estimated electricity charges according to trade, based on usage in MRT stations. The charges are based on expected power demands (type/specification and quantity of equipment) and operating hours (length of usage) of each unit. The charges listed are indicative. Actual charges will be calculated based on use and executed as per Clause 1.5 in the Licence Agreement.

Type of Trade	*Estimated Monthly Electricity Charges (Per Unit for 20m ²)
Grab & Go F&B	RM 1,000.00 - RM 4,000.00
Services / Others	RM 1,000.00 – RM 2,000.00

***Will vary depending on type and length of equipment use**

Table 2: Electricity charges according to trade

2.7 Retail Space for Rent

The units below are available for rent.

No	Station	Unit No.	Priority Type of Trade	Unit Area, m ²	Retail Location
1.	Damansara Damai	^K2005-1	Services/Grab & Go F&B	20.00	Unpaid Concourse
2.	Damansara Damai	^K2005-2	Convenience Store	20.00	Unpaid Concourse
3.	Damansara Damai	*K2005-3	Services	20.00	Paid Concourse
4.	Damansara Damai	*K2005-4	Services	20.00	Paid Concourse
5.	Sri Damansara Barat	^K2006-1	Convenience Store	24.00	Unpaid Concourse
6.	Sri Damansara Barat	^K2006-2	Services/Grab & Go F&B	18.00	Unpaid Concourse
7.	Sri Damansara Barat	*K2006-3	Services	20.00	Paid Concourse
8.	Sri Damansara Barat	*K2006-4	Services	20.00	Paid Concourse
9.	Sri Damansara Sentral	*K2007-1	Convenience Store	27.00	Unpaid Concourse
10.	Sri Damansara Sentral	^K2007-2	Services/Grab & Go F&B	16.00	Unpaid Concourse
11.	Sri Damansara Sentral	*K2007-3	Services	18.00	Paid Concourse
12.	Sri Damansara Sentral	*K2007-4	Services	18.00	Paid Concourse
13.	Sri Damansara Timur	*K2008-1	Services	20.00	Paid Concourse
14.	Sri Damansara Timur	*K2008-2	Convenience Store	20.00	Paid Concourse
15.	Metro Prima	^K2009-1	Services	20.00	Paid Concourse
16.	Metro Prima	*K2009-2	Convenience Store	30.00	Unpaid Concourse
17.	Kepong Baru	*K2010-1	Convenience Store	19.00	Paid Concourse
18.	Kepong Baru	*K2010-2	Services	19.00	Paid Concourse
19.	Jinjang	^K2011-1	Convenience Store	25.00	Unpaid Concourse
20.	Jinjang	*K2011-2	Services	20.00	Paid Concourse

No	Station	Unit No.	Priority Type of Trade	Unit Area, m ²	Retail Location
21.	Jinjang	*K2011-3	Services	20.00	Paid Concourse
22.	Sri Delima	*K2012-1	Convenience Store	21.00	Paid Concourse
23.	Sri Delima	*K2012-2	Services	18.00	Paid Concourse
24.	Kampung Batu	*K2013-1	Services	20.00	Paid Concourse
25.	Kampung Batu	*K2013-2	Services	20.00	Paid Concourse
26.	Kampung Batu	*K2013-3	Convenience Store	17.58	Unpaid Concourse

Note:

- a) All units are equipped with built-in fire protection system linked to the station Operations Control Centre (OCC). This feature has been incorporated into the station design to ensure added safety precautions.
- b) All retail units are provided with base shop specifications such as metered isolator (63 amp 3 phase), metered cold water piping, floor trap, fire roller shutter, emergency escape door and smoke detector.
- c) For retail unit **K2007-4 at Sri Damansara Sentral**, the retail unit is equipped with a gas cylinder for Fire Suppression Systems at corner end of the lot.

2.8 Retail Floor Plan

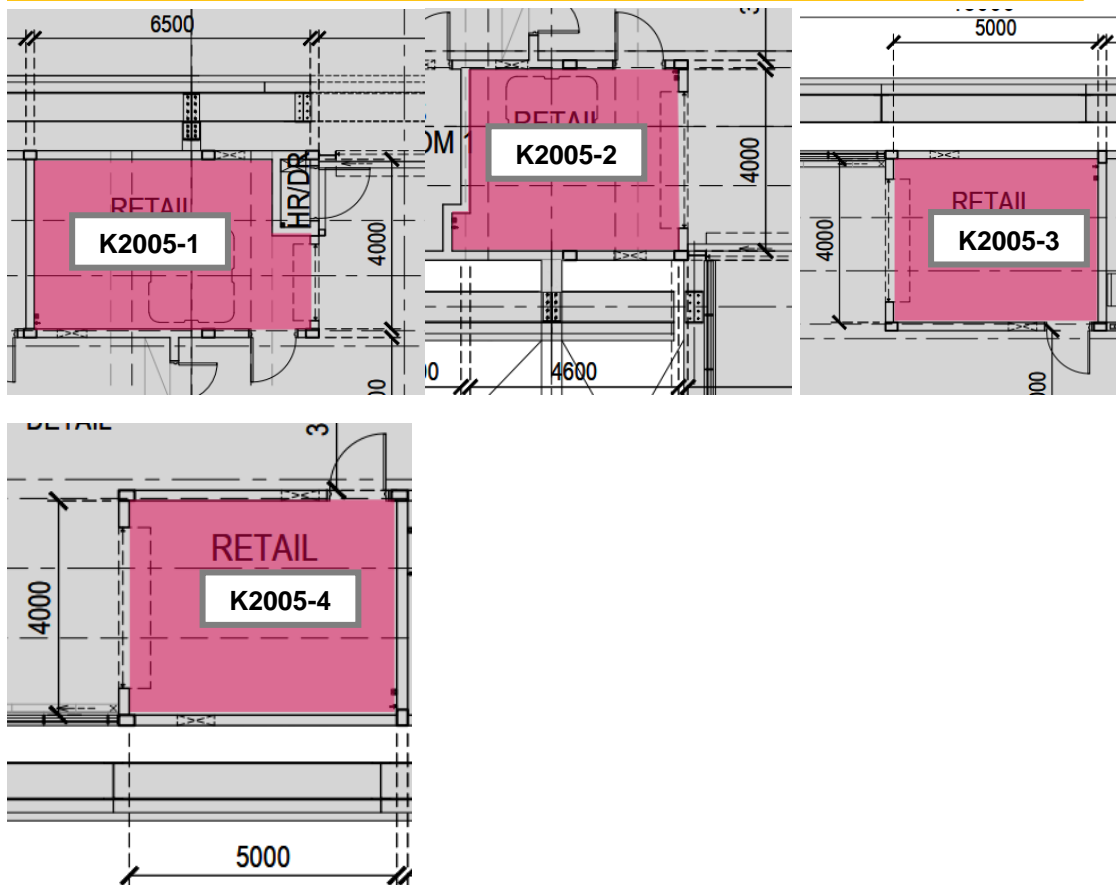
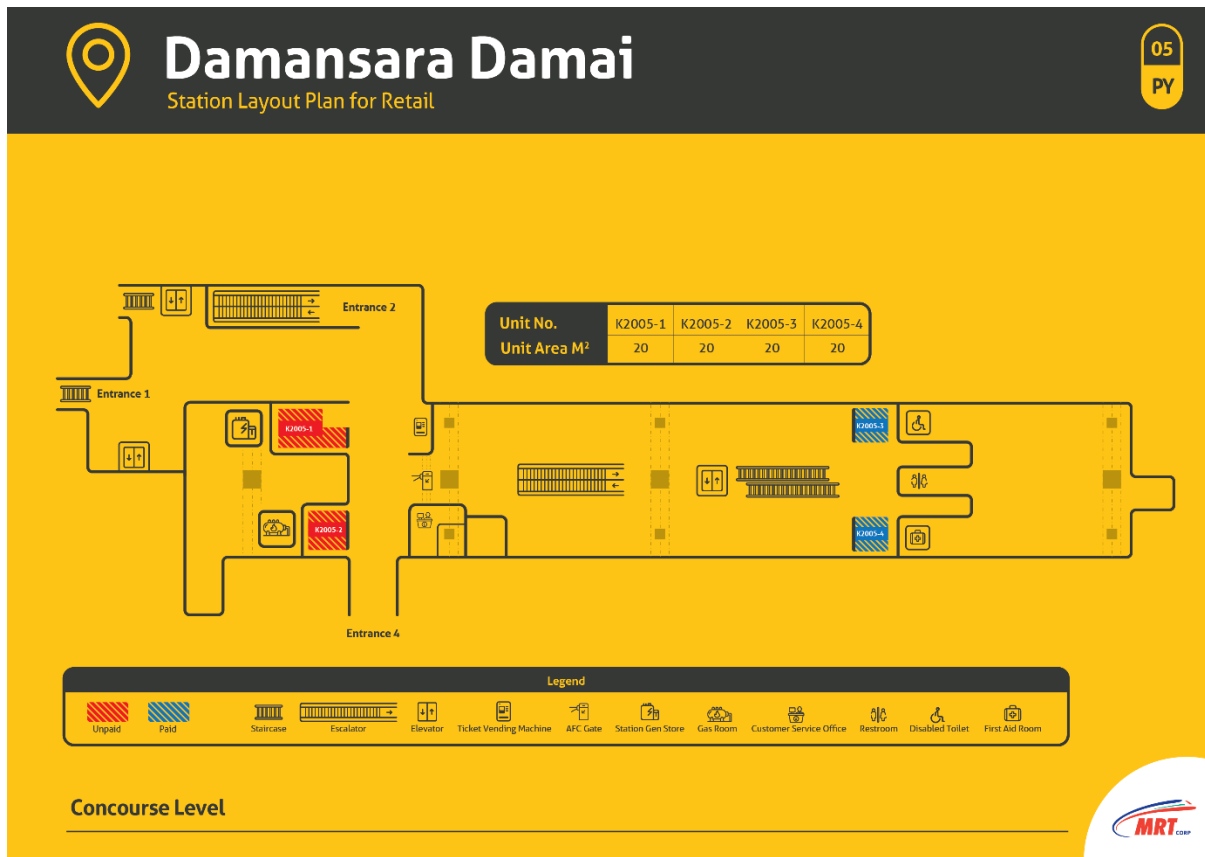



Sri Damansara Barat

Station Layout Plan for Retail

06
PY

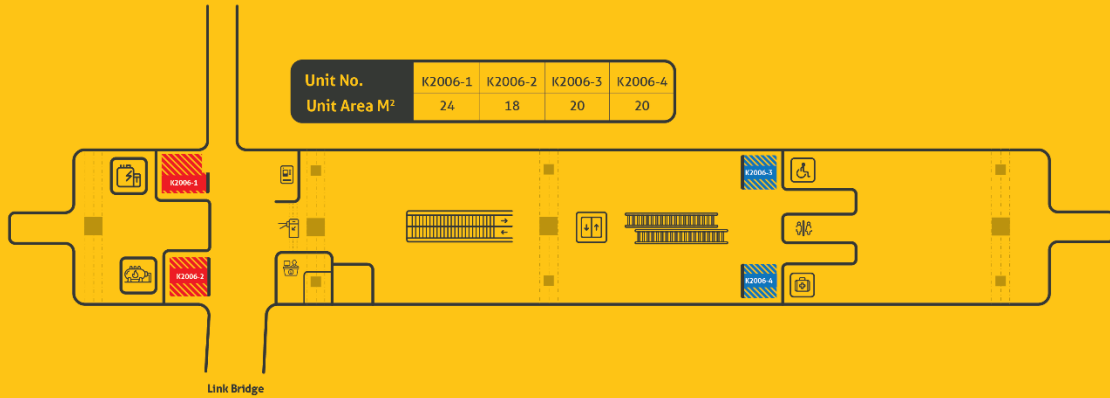

Unit No.	K2006-1	K2006-2	K2006-3	K2006-4
Unit Area M ²	24	18	20	20

Legend

- Unpaid (Red hatched)
- Paid (Blue hatched)
- Staircase
- Escalator
- Elevator
- Ticket Vending Machine
- AFC Gate
- Station Gen Store
- Gas Room
- Customer Service Office
- Restroom
- Disabled Toilet
- First Aid Room

Concourse Level

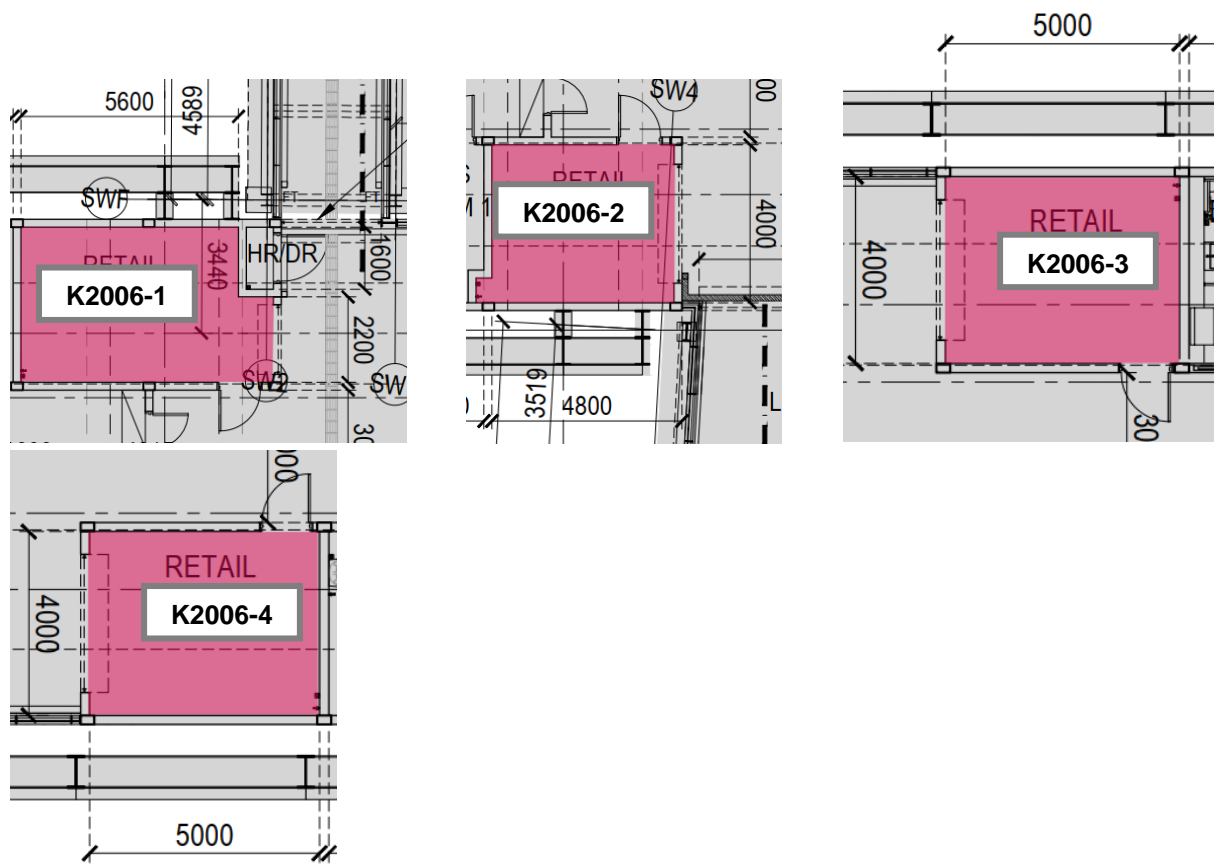



Sri Damansara Sentral

Station Layout Plan for Retail

07
PY

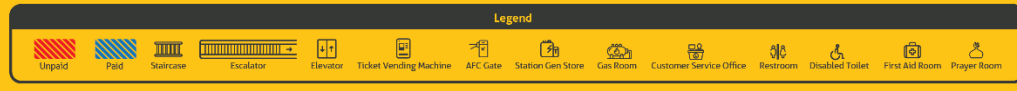
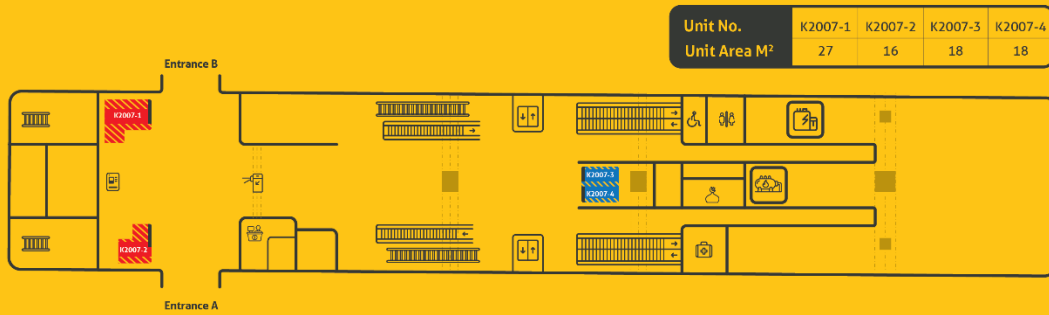

Concourse Level

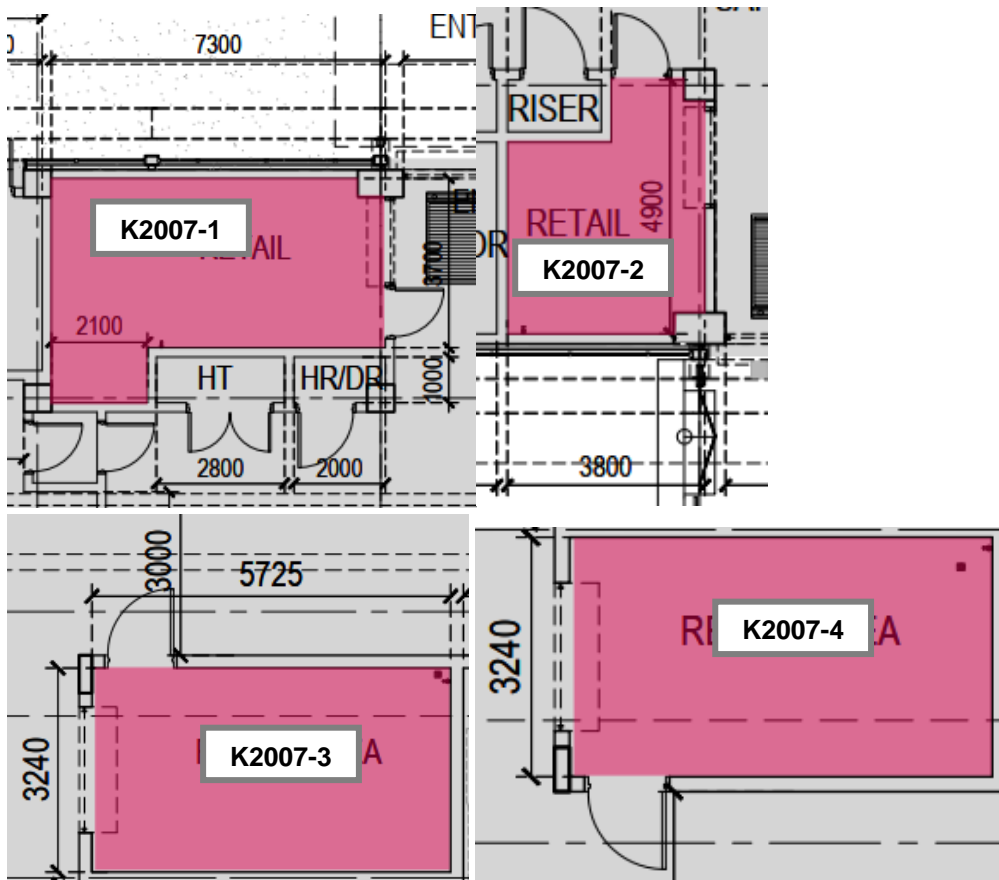

Note: For retail unit K2007-4 at Sri Damansara Sentral, the retail unit is equipped with a gas cylinder for Fire Suppression Systems at corner end of the lot.



Sri Damansara Timur

Station Layout Plan for Retail

08
PY

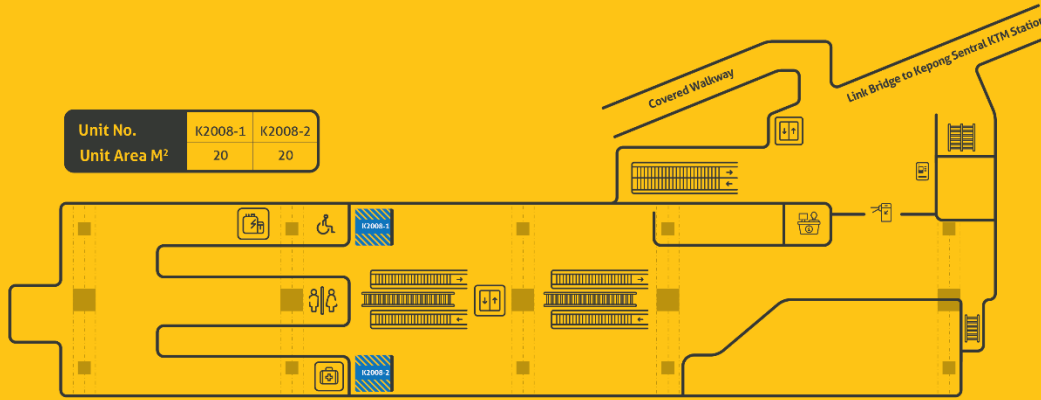

Unit No.	K2008-1	K2008-2
Unit Area M ²	20	20

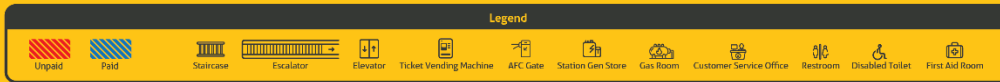

Concourse Level

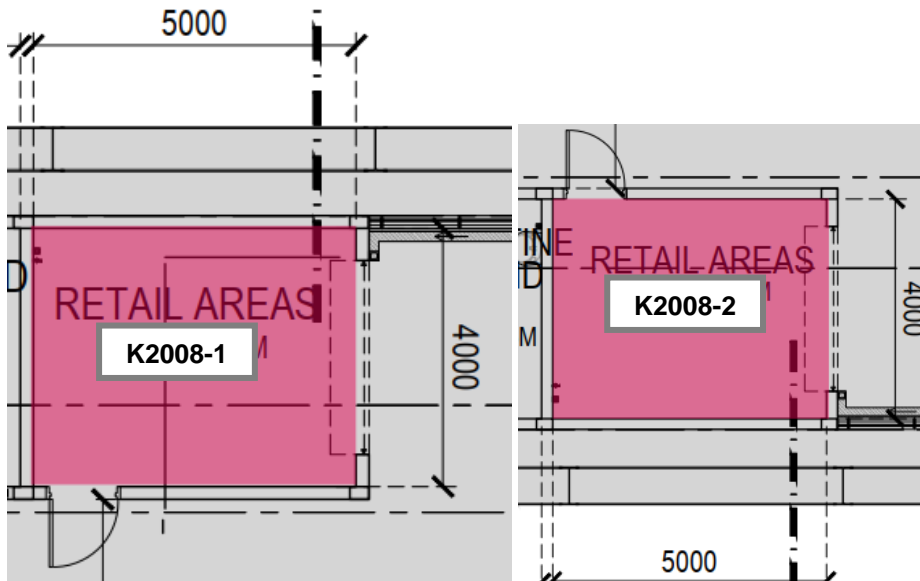



Metro Prima

Station Layout Plan for Retail

09
PY

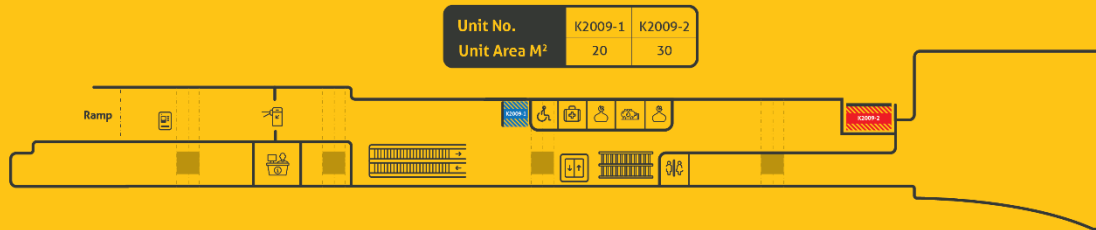

Concourse Level

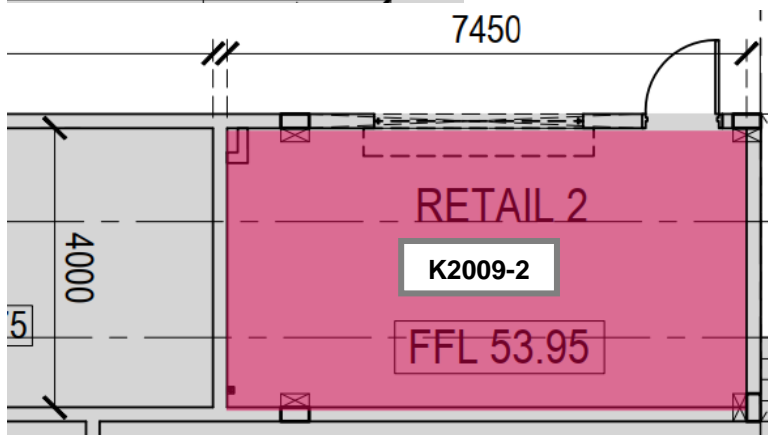
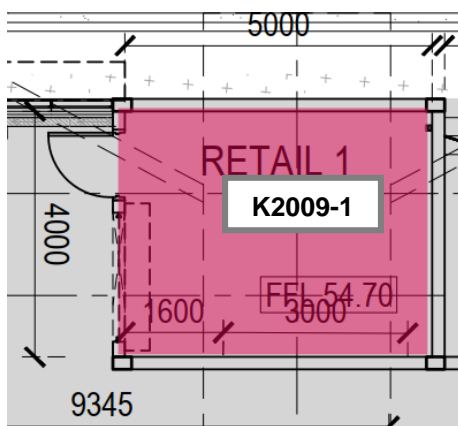



Kepong Baru

Station Layout Plan for Retail

10
PY

Unit No.	K2010-1	K2010-2
Unit Area M ²	19	19

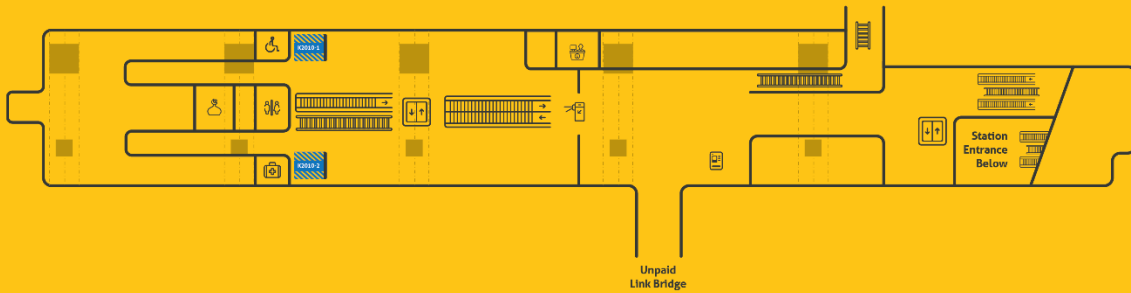

Concourse Level

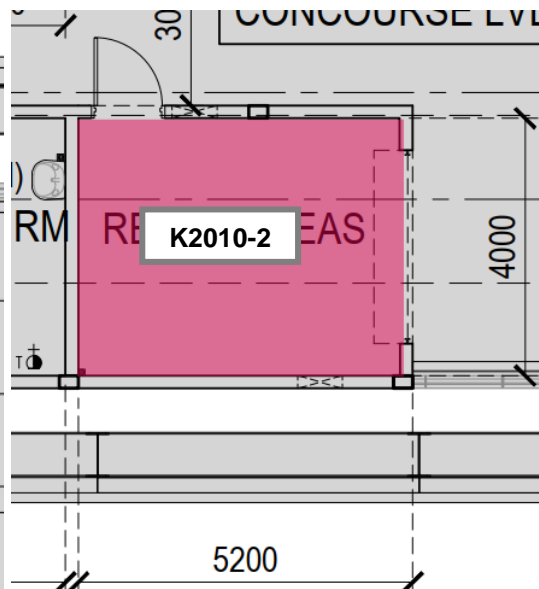
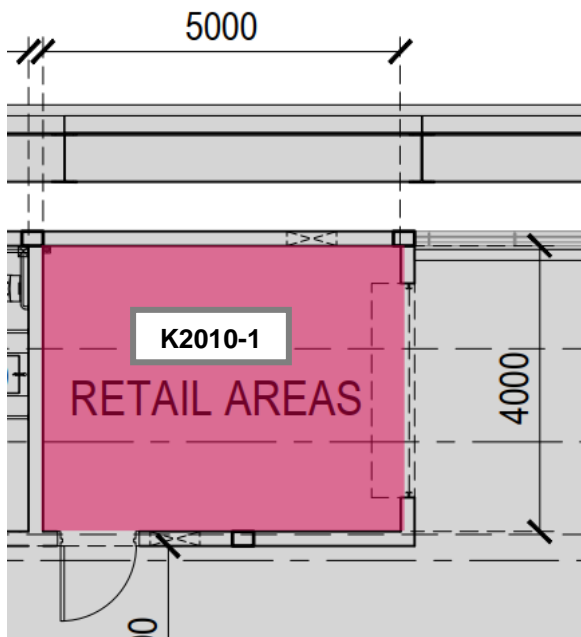

Jinjang

Station Layout Plan for Retail

11
PY

Unit No.	K2011-1	K2011-2	K2011-3
Unit Area M ²	25	20	20

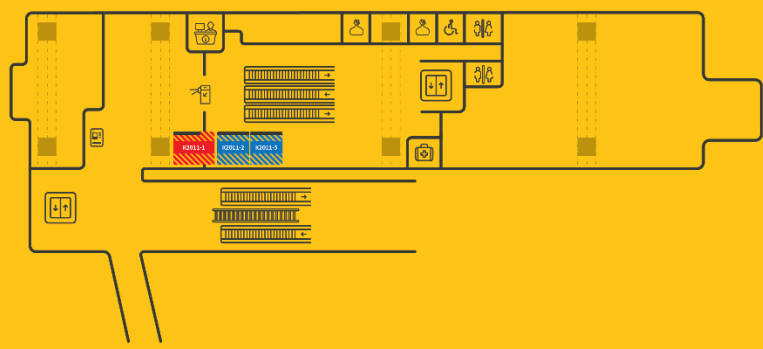

Legend

- Unpaid (Red hatched)
- Paid (Blue hatched)
- Staircase (Grey hatched)
- Escalator (White with arrows)
- Elevator (Square with 'E')
- Ticket Vending Machine (Machine icon)
- AFC Gate (Gate icon)
- Customer Service Office (Person icon)
- Restroom (Toilet icon)
- Disabled Toilet (Toilet with wheelchair icon)
- First Aid Room (First Aid icon)
- Prayer Room (Prayer icon)

Concourse Level

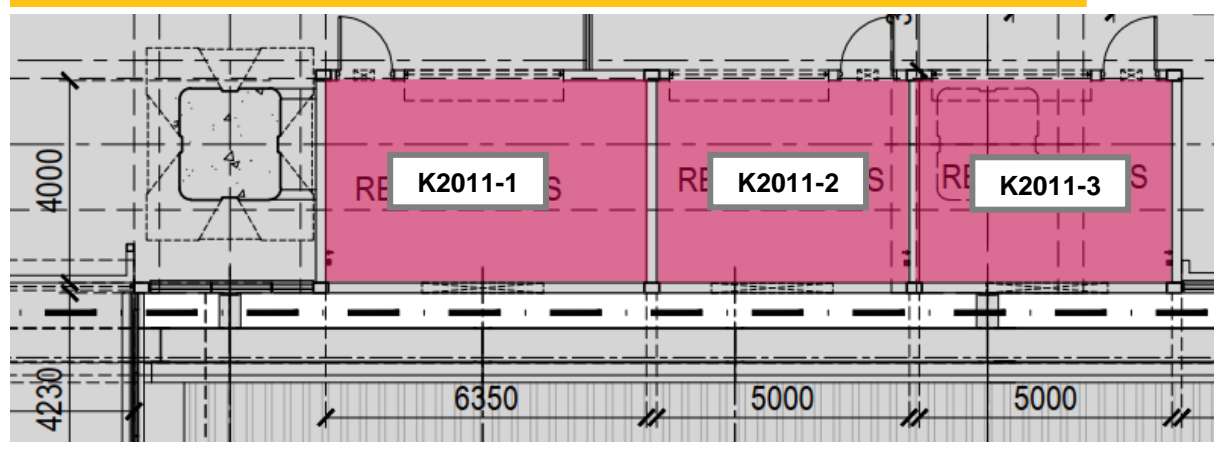

Sri Delima

Station Layout Plan for Retail

12
PY

Unit No.	K2012-1	K2012-2
Unit Area M ²	21	18

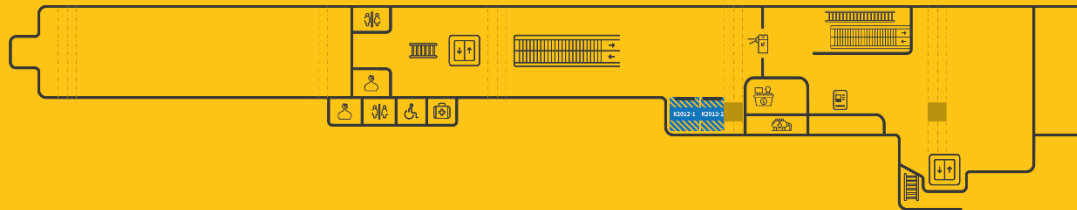

Concourse Level

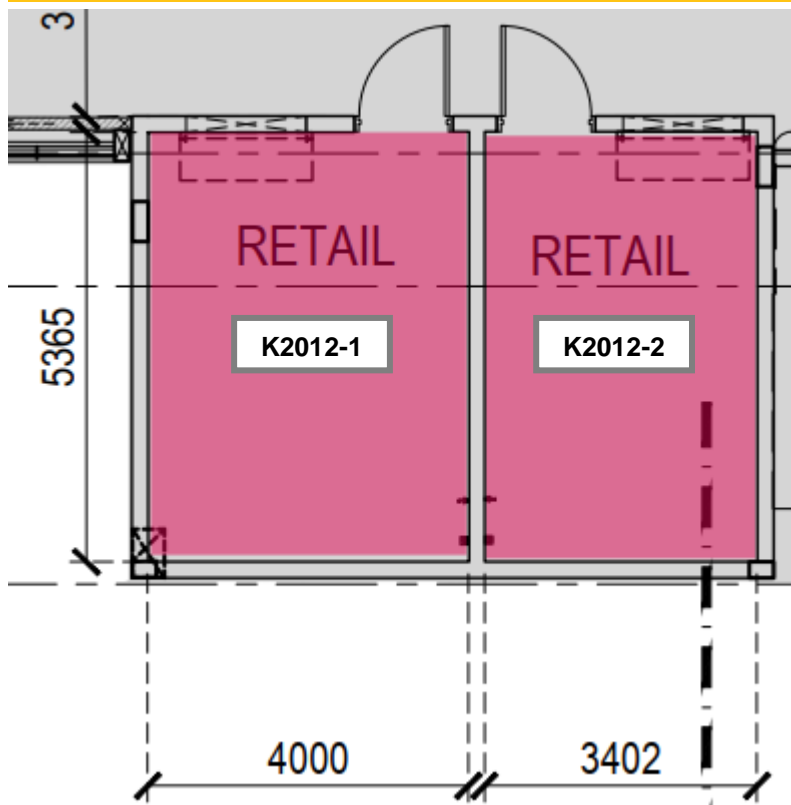



Kampung Batu

Station Layout Plan for Retail

13
PY

Unit No.	K2013-1	K2013-2	K2013-3
Unit Area M ²	20	20	17.58

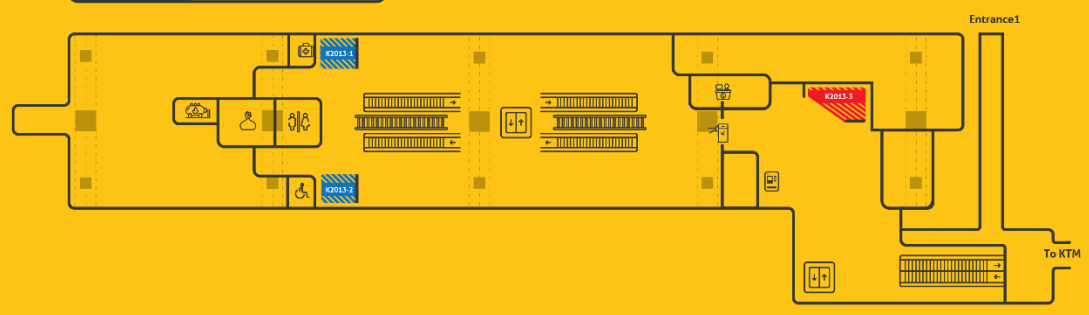

Legend

- Unpaid
- Paid
- Staircase
- Escalator
- Elevator
- Ticket Vending Machine
- AFC Gate
- Gas Room
- Customer Service Office
- Restroom
- Disabled Toilet
- First Aid Room
- Prayer Room

Concourse Level

